

# Soken Engineering

## Pack-Seal-Sell with Soken



# Innovative leading **heat sealing & packaging** machine manufacturer



## EasyPress Range

Our small machines are ideal for businesses with smaller production runs who want to get sealing quickly with lower upfront costs.

- Versatile solutions for sealing film and cardboard
- Great performance for low to medium volume users
- Cost effective for entry level and start-up producers

**HS20CF** [▶](#)

**HS22C** [▶](#)

**HS25CF** [▶](#)



## ShuttleMatic Range

For those looking to move to increased throughput with reduced effort. Deliver more product, faster with a semi-automatic operation.

- Semi-Automatic cardboard and film sealers
- Multiple pack sealing
- Great value, fast and durable

**HS34C** [▶](#)

**HS34CF** [▶](#)

**HS34ACF** [▶](#)

**HS35AC** [▶](#)

**HS35EC** [▶](#)

**HS36ACF** [▶](#)



## ProMatic Range

High speed, linear automatic sealing solutions for high volume users who need a fast, reliable and consistent sealer.

- Automatic film and cardboard sealers
- Efficient automated operation reduces labour and increases throughput
- Rapid speed and high quality presentation

**HS32CF-MAP** [▶](#)

**HS52C** [▶](#)

**HS55** [▶](#)

**HS60C** [▶](#)

**Temperature:** Automatic  
**Pressure:** Manual/User controlled  
**Time:** Manual/User controlled  
**Sealed pack removal:** Manual/User controlled

**Temperature:** Automatic  
**Pressure:** Automatic  
**Time:** Automatic\*  
**Sealed pack removal:** Manual/User controlled

**Temperature:** Automatic  
**Pressure:** Automatic  
**Time:** Automatic  
**Sealed pack removal:** Automatic

\*Excluding HS34C and HS34CF

## Packaging Supplies

- Latest cardboard packaging designs
- Sandwich, wrap, bloomer, salad, pasta boxes
- Ready meal trays & seal film, dual ovenables
- Bespoke printing designs & packaging
- Small and large volume - cost effective



**Bespoke tooling available for all machines**



# Soken HS20FC

## A versatile and simple sealer

### Our smallest combined tray and card heat sealer

**Ideal for:** Polypropylene (PP) & CPET, ready meal trays, plastic sandwich & snack packs & cardboard sandwich, wrap, salad and roll packs.

**Ideal users:** Small businesses, deli/coffee shops, start-ups ready-meals & snack food providers.

RAPID SEAL  
**300**  
PACKS / HOUR



Digital temperature gauge



Precision blade cutter

Visit Website

View Video

Plastic packs include



CPET Trays  
Various moulds available

Typical cardboard packs include



Sandwich Wedge

Tortilla / Wrap

Salad Tray

Bloomer Box

All Soken heat sealers are available with compatible packaging, spares facility and bespoke tooling options

### Key Features

- Seals both plastic and cardboard
- Accurate digital temperature control
- Precision blade cutter
- Hand operated robust hinge action
- Simple and quick to use
- Film retention bar
- Compact, stainless steel design
- Large range of pack tool options available
- Quick change tooling with easy to replace gaskets

### Specifications (width x depth)

- **Maximum seal area:** 180mm x 300mm
- **Weight:** 10kg
- **Height:** 550mm
- **Machine foot print:** 270mm wide 680mm long
- **Sealing rate:** Approx 300 packs per hour
- **Electrical requirement:** 230V 50Hz 1 phase 3 Amps (120V optional)

Is this machine right for you? Discover if it meets your need by using our configurator

Begin Configurator

# Soken HS22C

## A start-up manual board sealer

A small volume machine, designed specifically to seal all types of cardboard, including biodegradable packs

**Ideal for:** Sandwich wedges, bloomer, tortilla wraps, salad and pasta boxes.

**Ideal users:** Small start-up, low level production.



seal all types of cardboard



Visit Website



View Video



Typical cardboard packs include



Sandwich Wedge



Tortilla / Wrap



Salad Tray



Pasta Box

All Soken heat sealers are available with compatible packaging, spares facility and bespoke tooling options

### Key Features

- Window pack protection option
- Ability to seal wide range of board packaging
- Easy to operate
- Versatile and accurate digital temperature controller
- Hand operated, hinge action application
- Compact, stainless steel design

### Specifications (width x depth)

- **Maximum seal area:** 180 x 300mm
- **Weight:** 10kg
- **Height:** 550mm
- **Machine foot print:** 270mm wide 550mm long
- **Sealing rate:** Approx 300 packs per hour
- **Electrical requirement:** 230V 50Hz 1 phase 3 Amps (120V optional)

Is this machine right for you? Discover if it meets your need by using our configurator

Begin Configurator





# Soken HS25FC

## A manual film and card sealer

**A compact, flexible wider film / cardboard sealer offering greater flexibility with consistent results**

**Ideal for:** Polypropylene (PP) & CPET, ready meals, plastic sandwich packs, snack packs.

**Ideal users:** Butchers, catering production units.



Hand operated hinge action application



Precision blade cutter

Visit Website



View Video



Plastic packs include



CPET Trays  
Various moulds available

Typical cardboard packs include



Sandwich Wedge

Tortilla / Wrap

Salad Tray

Bloomer Box

**All Soken heat sealers are available with compatible packaging, spares facility and bespoke tooling options**

### Key Features

- Ability to seal plastic film to packs
- Precision blade cutter
- Hand operated, hinge action application
- Easy and simple to use
- Versatile and accurate digital temperature controller
- Compact, stainless steel design
- Wider seal plate option

### Specifications (width x depth)

- **Maximum seal area:** 280 x 320mm
- **Weight:** 14kg
- **Height:** 550mm
- **Machine foot print:** 370mm wide 720mm long
- **Sealing rate:** Approx 400 packs per hour
- **Electrical requirement:** 230V 50Hz 1 phase 5 Amps (120V optional)

**Is this machine right for you? Discover if it meets your need by using our configurator**

Begin Configurator





## Soken HS34C

# A medium volume cardboard sealer

**Fast and reliable, heat sealing multiple cardboard packs simultaneously with minimal effort**

**Ideal for:** Cardboard sandwich, pasta and salad boxes, tortilla wrap, noodle boxes and component blister packs.

**Ideal users:** Mid-range producers.

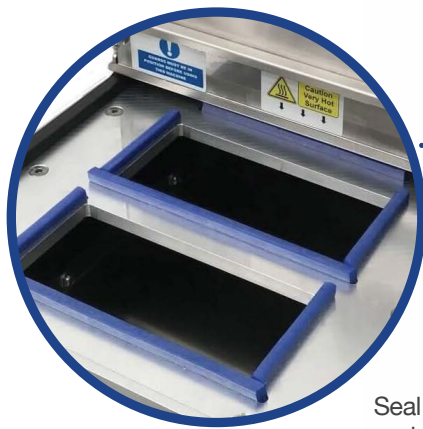

Seal multiple packs simultaneously



Typical cardboard packs include



Sandwich Wedge



Tortilla / Wrap



Salad Tray

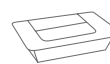

Pasta Box

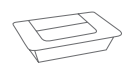

Bloomer Box



Blister Packs

Visit Website



View Video



All Soken heat sealers are available with compatible packaging, spares facility and bespoke tooling options

### Key Features

- Fast, manual operation with over-centre handle for consistent controlled pressure
- Versatile and accurate digital temperature controller
- Compact stainless steel design for multiple output packs sealed simultaneously
- Variety of tooling options available
- Tool drawer operation
- Quick change tooling facility
- Table top use

### Specifications (width x depth)

- **Maximum seal area:** 240 x 220mm
- **Weight:** 25kg
- **Height:** 380mm
- **Machine foot print:** 370mm(w) 610mm(l) 370mm(h)
- **Sealing rate:** 400 packs per hour
- **Electrical requirement:** 230V 50Hz 1 phase 4 Amps (120V version available)

Is this machine right for you? Discover if it meets your need by using our configurator

Begin Configurator





# Soken HS34CF Profile cut manual film sealer

**A versatile manual profile cut sealer for foil, plastic and cardboard providing absolute seal integrity**

**Ideal for:** Foil and plastic trays and pots, cardboard sandwich, pasta and salad boxes, pots, tortilla wrap, noodle boxes and component blister packs.

**Ideal users:** Small to mid-range producers.



Tooling options allow 2 packs to be sealed simultaneously



Semi and full profile cut sealer



Fast, manual operation

Visit Website

View Video

Plastic packs include



CPET Trays  
Various moulds available

Typical cardboard packs include



Sandwich  
Wedge

Tortilla /  
Wrap

Salad Tray

Bloomer  
Box

Blister  
Packs

**All Soken heat sealers are available with compatible packaging, spares facility and bespoke tooling options**

## Key Features

- Semi and full profile cut film sealer
- Ability to seal latest foil, plastic trays, pots and cardboard laminates
- Automatic film seal transport system
- Fast, manual operation with over-centre handle for consistent controlled pressure
- Versatile and accurate digital temperature controller
- Compact stainless steel design for multiple output
- 2 packs sealed simultaneously (depending on pack size)

## Specifications (width x depth)

- **Maximum seal area:** 220 x180mm
- **Weight:** 30kg
- **Height:** 420mm
- **Machine foot print:** 370mm(w) 610mm(l) 420mm(h)
- **Sealing rate:** 200/400 packs per hour (depending on pack size)
- **Electrical requirement:** 230V 50Hz 1 phase 4 Amps (120V version available)

**Is this machine right for you? Discover if it meets your need by using our configurator**

Begin Configurator



# Soken HS34ACF Semi-automatic board sealer

**High pressure and temperature film lid seal system. An all in one sealer, with effortless automatic operation**

**Ideal for:** Foil and plastic trays and pots, cardboard sandwich, pasta and salad boxes, pots, tortilla wrap, noodle boxes and component blister packs.

**Ideal users:** Small to mid-range producers.

New tooling now available for pots



Visit Website

View Video

Plastic packs include



CPET Trays  
Various moulds available

Typical cardboard packs include



Sandwich  
Wedge

Tortilla /  
Wrap

Salad Tray

Bloomer  
Box

Blister  
Packs

**All Soken heat sealers are available with compatible packaging, spares facility and bespoke tooling options**

## Key Features

- Semi-automatic, accurate, profile cut film sealer
- Ability to seal latest foil, plastic trays, pots and cardboard laminates
- Automatic film seal transport system
- Fast, effortless operation
- Versatile and accurate digital temperature controller and seal timer
- Compact stainless steel design for multiple output
- 2 packs sealed simultaneously (depending on pack size)
- Variety of tooling options available\*

\*Bespoke tooling facility available

## Specifications (width x depth)

- **Maximum seal area:** 220 x180mm
- **Weight:** 30kg
- **Height:** 420mm
- **Machine foot print:** 370mm(w) 610mm(l) 420mm(h)
- **Sealing rate:** 200/400 packs per hour (depending on pack size)
- **Electrical requirement:** 230V 50Hz 1 phase 4 Amps (120V version available)
- **Air supply requirement:** Minimum 2CFM at 6 Bar

**Is this machine right for you? Discover if it meets your need by using our configurator**

Begin Configurator



# Soken HS35AC

## Semi-automatic, high volume board sealer

Effortlessly heat seals up to 4 cardboard packs simultaneously providing optimum seal integrity.

**Ideal for:** Cardboard sandwich, baguettes, pasta and salad boxes, tortilla wrap and noodle boxes.

**Ideal users:** Mid-range producers.



Optional bespoke trolley for ease of mobility and storage



Typical cardboard packs include

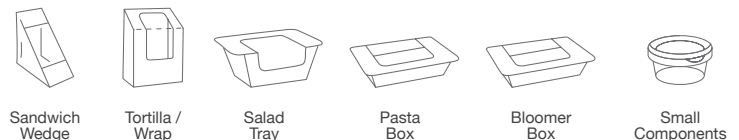

Visit Website



View Video



All Soken heat sealers are available with compatible packaging, spares facility and bespoke tooling options

### Key Features

- Fast semi-automatic operation
- Versatile and accurate digital temperature controller and timer
- Compact stainless steel design for multiple output
- Large and small packs sealed simultaneously
- Variety of tooling options available
- Tool drawer plate operation
- Quick change tooling facility

### Specifications (width x depth)

- **Maximum seal area:** 405 x220mm
- **Weight:** 35kg
- **Height:** 380mm
- **Machine foot print:** 465mm(w) 610mm(l) 360mm(h)
- **Sealing rate:** Approx 800 packs per hour
- **Electrical requirement:** 230V 50Hz 1 phase 8 Amps (120V version available)
- **Air supply requirement:** Minimum 2 cfm at 6 bar

Is this machine right for you? Discover if it meets your need by using our configurator

Begin Configurator





# Soken HS35EC Fully electric board sealer

**A fast, flexible and efficient fully electric, multiple pack, cardboard heat sealer**

**Ideal for:** Cardboard sandwich, baguettes, pasta and salad boxes, tortilla wrap, noodle boxes and small components.

**Ideal users:** Mid-range users, safety sensitive locations e.g. airports.



Flexible and efficient sealing

Tooling options available

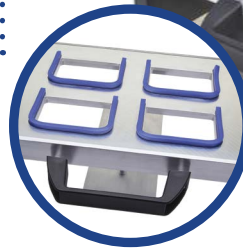

RAPID SEAL  
**800**  
PACKS / HOUR

ALMOST SILENT



Visit Website

View Video

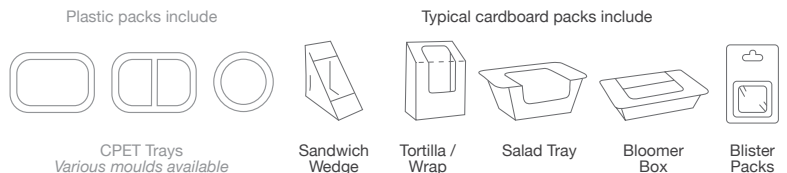

**All Soken heat sealers are available with compatible packaging, spares facility and bespoke tooling options**

## Key Features

- Simple to use
- Versatile and accurate digital temperature controller and seal timer
- Virtually silent electric operation
- Seals up to 4 packs simultaneously
- Fast, semi-automatic production
- Compact stainless steel design for multiple output
- Large and small packs sealed simultaneously
- Variety of tooling options available\*
- Tool drawer plate operation

\*Optional bespoke trolley available for mobility and tooling storage

## Specifications (width x depth)

- **Maximum seal area:** 405 x220mm
- **Weight:** 42kg
- **Height:** 550mm
- **Machine foot print:** 465mm(w) 610mm(l) 590mm(h)
- **Sealing rate:** Approx 800 packs per hour
- **Electrical requirement:** 230V 50Hz 1 phase 8 Amps (120V optional)

**Is this machine right for you? Discover if it meets your need by using our configurator**

Begin Configurator



## Soken HS36ACF

# Semi-automatic sealer for ready meals

Offering minimum labour and maximum output – sealing in seconds using compressed air.

**Ideal for:** Ready meals, sandwich, baguettes, pasta and salad boxes, tortilla wrap, noodle boxes and small components.

**Ideal users:** Mid-range users.



Seal ready meals with minimum effort



Visit Website



View Video



Plastic packs include



CPET Trays  
Various moulds available

Typical cardboard packs include



Sandwich  
Wedge

Tortilla /  
Wrap

Salad Tray

Bloomer  
Box

Small  
Components

All Soken heat sealers are available with compatible packaging, spares facility and bespoke tooling options

### Key Features

- Semi-automatic, accurate, profile cut film sealer
- Ability to seal latest foil, plastic trays, pots and cardboard laminates
- Automatic film seal transport system
- Fast, effortless operation
- Versatile and accurate digital temperature controller and seal timer
- Compact stainless steel design for multiple output
- 4 packs sealed simultaneously (depending on pack size)
- Variety of tooling options available\*

\*Bespoke tooling facility available

### Specifications (width x depth)

- **Maximum seal area:** 425 x 180mm
- **Weight:** 45kg
- **Height:** 530mm
- **Sealing rate:** Approx 1,000 packs per hour
- **Volts:** 220-240
- **Hz:** 50 - Phase 1
- **Amps:** 8
- **Watts:** 2000
- **Air supply:** 6BAR 2CFM

Is this machine right for you? Discover if it meets your need by using our configurator

Begin Configurator





# Soken HS32CF-MAP Modified atmosphere packaging

## Extending the shelf life of numerous heat sealed food-to-go packaged products

The ideal solution for an inexpensive and professional vacuum packaging with trays and combine ease of use with reliability.

Characterised by its simplicity of use and speed in packaging. Equipped with a digital panel with 10 programs.

**It can pack:** Solids, liquids and delicate foods.



Equipped with a gas flush system

Digital panel with 10 programs



**99.99%**  
VACUUM  
LEVEL  
ACHIEVED

Suitable for packing:



Solids



Liquids



Delicate Foods

Visit Website



All Soken heat sealers are available with compatible packaging, spares facility and bespoke tooling options

### Key Features

- Stainless steel design
- Achieves a vacuum level up to 99.99% and is equipped with a gas flush system to inject inert gas up to 100% and pack in modified atmosphere.
- Standard tooling - 1 x ½ Gastronorm (325x260 mm), 2 x ¼ Gastronorm (160x260 mm), 4 x 1/8 Gastronorm (165x120 mm). Many other tools available to suit standard and bespoke packaging, including card and eco-variants. Please ask for more details.

### Specifications (width x depth)

- **Vacuum Chamber Dimensions:** 380 x 205 x 126mm
- **Dimensions:** 497 x 769 x 1158mm
- **Weight:** 131kg
- **Voltage:** 220-240V / 50-60Hz - 2850W
- **Vacuum Pump:** 25mc/h

Is this machine right for you? Discover if it meets your need by using our configurator

Begin Configurator





# Soken HS52C Automatic cardboard sealer

## Linear automatic, rapid, high volume, cardboard heat sealer with indexing system

**Ideal for:** Sandwich, wraps and salad boxes.

**Ideal users:** High volume food-to-go manufacturer.

automatic pack eject system

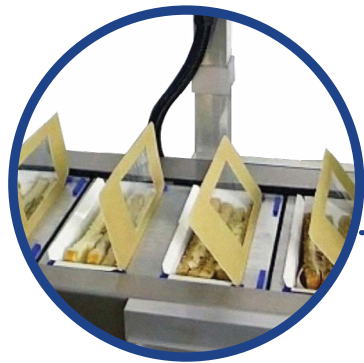
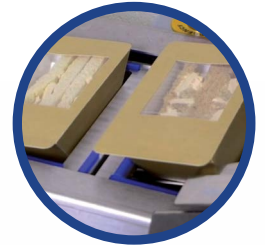

High volume sealing



Precise control



Visit Website



View Video



Typical cardboard packs include



Sandwich Wedge



Tortilla / Wrap



Salad Tray



Pasta Box

All Soken heat sealers are available with compatible packaging, spares facility and bespoke tooling options

### Key Features

- Seal speed: Up to 1400 packs per hour
- Seal temperature accurately maintained
- Accurate digital seal timer
- Precise control of high seal pressure
- Exact index location and dedicated top and bottom tooling secures positioning
- Product protection at high seal temperature
- Optional label and printer application facility function
- Labour saving

### Specifications (width x depth)

- **Maximum seal area:** 200 x 230mm
- **Weight:** 200kg
- **Height:** 1600mm
- **Width:** 600mm
- **Length:** 2500mm
- **Sealing rate:** 1,400 packs per hour
- **Air supply:** 6BAR 2CFM
- **Power:** 230V 50Hz 1 phase 6 Amps (120V optional)

Is this machine right for you? Discover if it meets your need by using our configurator

Begin Configurator





# Soken HS55

## Linear automatic film and card sealer

**Seals up to 2,800 packs per hour of the latest eco-friendly trays and films with zero film waste during production**

**Ideal for:** Ready meals, fresh foods, salad trays, convenience foods and sandwich packs.

**Ideal users:** Medium to large ready meal and convenience food producers.



Touch screen HMI setup

Zero film waste during production



**RAPID SEAL**  
**2800**  
**PACKS / HOUR**



Visit Website



Plastic packs include



CPET Trays  
Various moulds available

Typical cardboard packs include



Sandwich Wedge



Tortilla / Wrap



Salad Tray

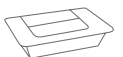

Bloomer Box

**All Soken heat sealers are available with compatible packaging, spares facility and bespoke tooling options**

### Key Features

- Touch screen HMI setup
- Digital temperature control
- Accurate digital seal duration control
- Manual index or automatic mode, selectable on HMI
- Automatic film feed system with zero-waste
- Multiple tooling plate options for different tray sizes
- Adjustable stepper-motor controlled indexing
- Easy-access for maintenance and cleaning
- Quick change tooling plates (approx 5-10mins)

### Specifications (width x depth)

- **Maximum seal area:** 260 x 300mm
- **Weight:** 250kg
- **Height:** 1430mm
- **Width:** 600mm
- **Length:** 2450mm
- **Capacity:** up to 2,800 packs per hour, depending on tray size and film
- **Electrical requirement:** 230V 1PH 13A
- **Pneumatic requirement:** 6BAR Clean and dry air 2CFM

**Is this machine right for you? Discover if it meets your need by using our configurator**

Begin Configurator





## Soken HS60

# High speed automatic cardboard sealer

**Linear automatic, rapid action, twin head line delivery system, providing efficient production with minimal labour**

**Ideal for:** Cardboard sandwich packs.

**Ideal users:** High volume food-to-go manufacturer.

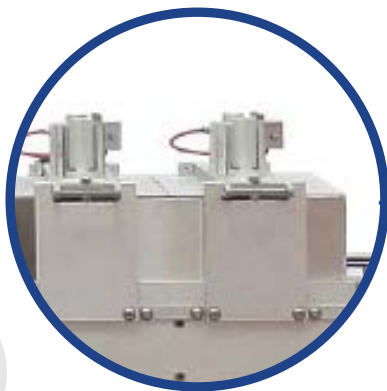

Twin head line delivery system

Precise control



automatic pack eject system

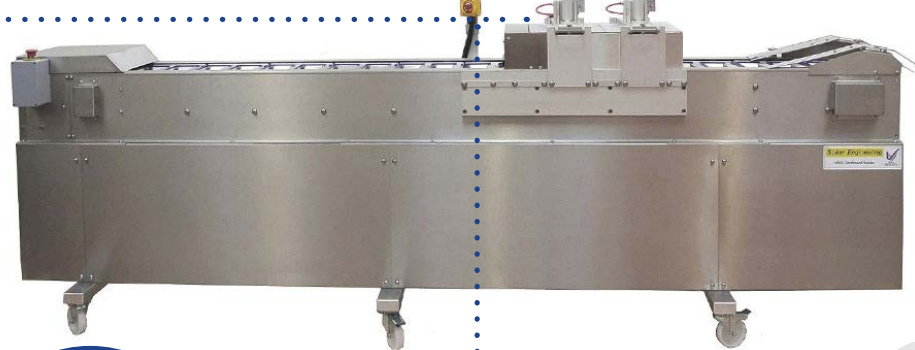

Typical cardboard packs include



Sandwich Wedge



Tortilla / Wrap



Salad Tray

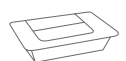

Pasta Box

Visit Website



View Video



All Soken heat sealers are available with compatible packaging, spares facility and bespoke tooling options

### Key Features

- Seal speed: up to 2200 sandwich packs per hour
- Twin head production line system
- Seal temperature accurately maintained
- Accurate digital seal time (additional 5 second seal option)
- Precise control of high seal pressure
- Specific index location and dedicated two part tooling ensures accurate positioning and sealing
- Product protection at high seal temperature
- Optional label & printer application facility/function
- Labour saving

### Specifications (width x depth)

- **Maximum seal area:** 200 x 230mm
- **Weight:** 200kg
- **Height:** 1730mm
- **Width:** 600mm
- **Length:** 3250m
- **Capacity:** Approx 2,200 packs per hour
- **Air supply:** 5 cfm at 6 bar
- **Power:** 230V 50Hz 1 phase 10 Amps

Is this machine right for you? Discover if it meets your need by using our configurator

Begin Configurator





Soken Engineering Ltd  
9 Ardglen Industrial Estate  
Whitchurch, Hampshire  
RG28 7BB, UK

Tel: +44 (0) 1256 892194  
info@sokenengineering.com

[www.sokenengineering.com](http://www.sokenengineering.com)